

USE AND MAINTENANCE MANUAL



AIR COOLED CONDENSING AND REMOTE CONDENSING UNIT MCE-R / MCH

TABLE OF CONTENTS

1. INTRODUCTION	pag. 2
1.1 Manual content	pag. 2
1.2 Safety marks	pag. 2
1.3 Referring standards	pag. 2
1.4 Warranty	pag. 2
1.5 Readers of the Manual	pag. 3
2. MAIN SAFETY RULES	pag. 3
2.1 Main warnings	pag. 3
2.2 Allowed use	pag. 3
2.3 Forbidden use	pag. 3
2.4 Dangerous areas	pag. 4
3. GENERAL DESCRIPTION	pag. 4
3.1 Chillers features and interpreting key	pag. 4
3.2 Main components	pag. 5
3.3 Cooling circuit	pag. 7
3.4 Technical specification	pag. 9
3.5 Dimensional drawings	pag. 9
3.6 Main accessories	pag. 9
4. INSTALLATION	pag. 11
4.1 Identification tag	pag. 11
4.2 Reception and inspection	pag. 11
4.3 Handling	pag. 12
4.4 Arrangements and placing	pag. 14
4.5 Cooling connections	pag. 18
4.6 System vacuum and charge execution.....	pag. 19
4.7 Electric connections.....	pag. 21
5. OPERATION	pag. 24
5.1 First check	pag. 25
5.2 First startup	pag. 25
5.3 Microprocessor setting	pag. 25
5.4 Fault alarm and display system	pag. 25
5.5 Troubleshooting	pag. 25
5.6 Routine maintenance	pag. 26
5.7 Precautionary planned maintenance	pag. 28
5.8 Special maintenance	pag. 35
6. DISMANTLING	pag. 35

1. INTRODUCTION

1.1 Manual content

The present handbook, originally written in Italian, was completed in compliance with the "Machinery Directive". It contains all the necessary information for carrying out without any risk transportation, installation, startup, operation, setting, maintenance and dismantling of the air cooled condensing units of series MCE - R / MEH.

Should you have any doubt on the correct understanding of these instructions, please contact the Manufacturer in order to get further explanations.

1.2 Safety marks

The following safety marks are used in this manual to draw attention to all useful information in order to avoid any dangerous situation which could be unsafe and harmful for people, could damage equipment and environment besides breaking the unit.



It means operation and behaviour not allowed.



It means danger or risk to people, things or environment.



It means an electrical danger.



It means a warning about important functions or useful information. Pay the maximum attention to the paragraphs marked with this symbol.

1.3 Referring standards

The units of MCE - R / MEH series are designed and manufactured in compliance with the relevant European Directives and in particular, they meet the "Essential Safety Requirements" as set out in the European Directive 89/392/CEE, and further amendments, as attested by the CE mark that is on each unit.

As a matter of fact, the units are certified by the manufacturer and are provided together with the CE Declaration of Conformity which is attached to the present manual.

Where applicable, the units mentioned in this handbook are in conformity with the directive 97/23/CE (PED), concerning the pressure devices.

1.4 Warranty

The manufacturer warrants the air cooled water chillers and heat pumps according to what stated on his general sales terms or according to what else explicitly agreed.

The Manufacturer Warranty is void in case the guidance of this manual has not been carefully respected.

The manufacturer refuses all responsibility for any damage to people, animals, things or environment, caused by incorrect installation, maintenance or setting or misuse of the machine. It is considered as "misuse" of the machine any use not explicitly allowed in this manual.



Warning: on the first startup, duly fill in the relevant report attached to this manual and send a copy to Emicon A.C. (Customer Service), in order to make the warranty valid.

1.5 Readers of the Manual

This manual and all its attachments are supplied with the described unit. The manual must be kept by the machine's owner in a proper place. To this end, a plastic bag where to store the manual has been placed inside the machine so that it can be always easily accessible for consultation and at the same time, it can be preserved in a good state.

All people authorized to operate with the unit, in particular, all technicians assigned to the unit maintenance, must know all information and instructions contained in this manual.

In case the manual is lost or deteriorated, a new copy must be requested directly to the manufacturer.

2. MAIN SAFETY RULES

2.1 General warnings



Read carefully the whole handbook before performing any operation on the unit. Only qualified and trained technicians must perform any operation on the machine.



Do not touch the machine if with bare feet or with humid or wet parts of the body.

Do not perform any cleaning operation before the main switch is "OFF" and power line disconnected.

Do not spread, leave unattended or to the reach of children any packaging material (carton box, staples, plastic bags, etc.) as they may be a source of danger.

2.2 Allowed use

MCE - R / MEH: condensing unit intended for cooled air or water production if connected to evaporating unit to be used both in air-conditioning and/or industrial systems. They are designed for external installation (units with axial fans) or for internal installation (units with centrifugal fans).

2.3 Forbidden use

Do not use the machine:

- Ø For other use than that described in paragraph 2.2;
- Ø When it is exposed to rainfall, especially when the unit is designed for internal installation;
- Ø in atmosphere with high risk of fire or explosion;
- Ø in spaces with corrosive atmosphere;
- Ø to heat or cool aggressive fluids for copper, carbon steel and stainless steel.



Any operation on the unit must be carried out in compliance with local technical standards.

2.4 Dangerous areas

On the unit there are dangerous areas for electric risk and hot temperatures.

The unit can be closed by case panels; in this case the dangerous parts inside the unit are not accessible from outside. Only qualified and trained personnel can remove the covering panels. The unit is supplied with the cooling circuit already charged with pressure gas and therefore it is necessary to pay the maximum attention in order to avoid accidental release of the gas in the atmosphere.

3. GENERAL DESCRIPTION

3.1 Characteristics of the condensing units MCE - R / MCH

The units of series MCE - R / MCH are supplied with nitrogen charged cooling circuit; they are functionally tested at the factory.

Interpreting key for the initials used to mark the units:

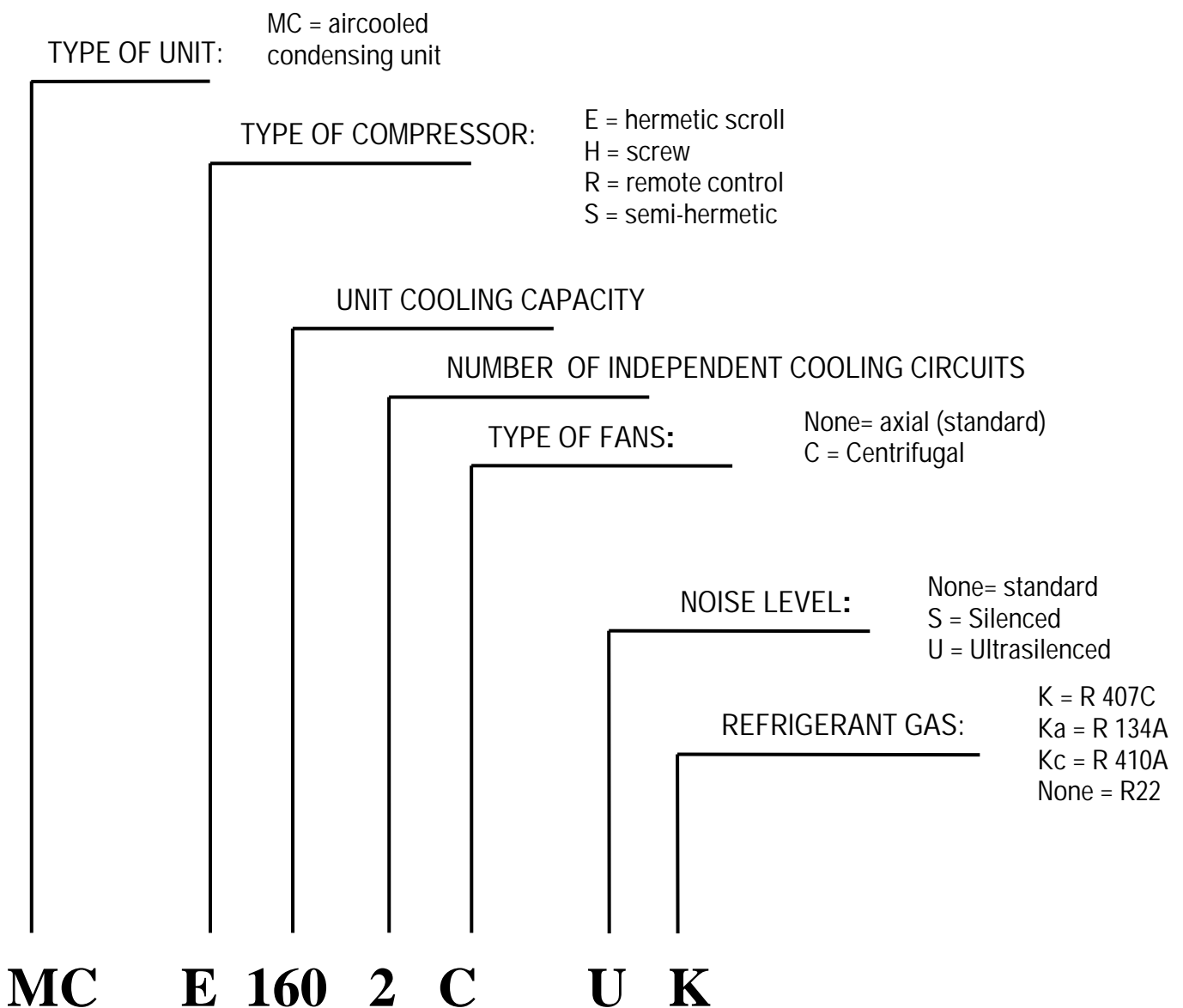

3.2 Main components

The units of MCE / H / R series are made of the following main components:

- Ø The housing is made of galvanized and painted pressure bended steel plate or housing made of aluminium section;
- Ø Compressors, installed on rubber vibration dampers and equipped with oil sump heater,
- Ø Weld-brazed plate evaporator or shell & tube evaporator with heat insulation;
- Ø Heat exchange coil made of aluminium fins and copper pipes;
- Ø Cooling circuit composed of: thermostatic expansion valve, sight glass, dehydrating filter, safety device, anti-freeze thermostat, high and low pressure switches;
- Ø Electric panel in compliance with CE norms and provided with main disconnecting switch; thermal and amperometric protections, contactors, auxiliary low voltage circuit, terminal board;
- Ø The control microprocessor allows to manage the unit operation and its alarms.

Condensing unit version MCE / R

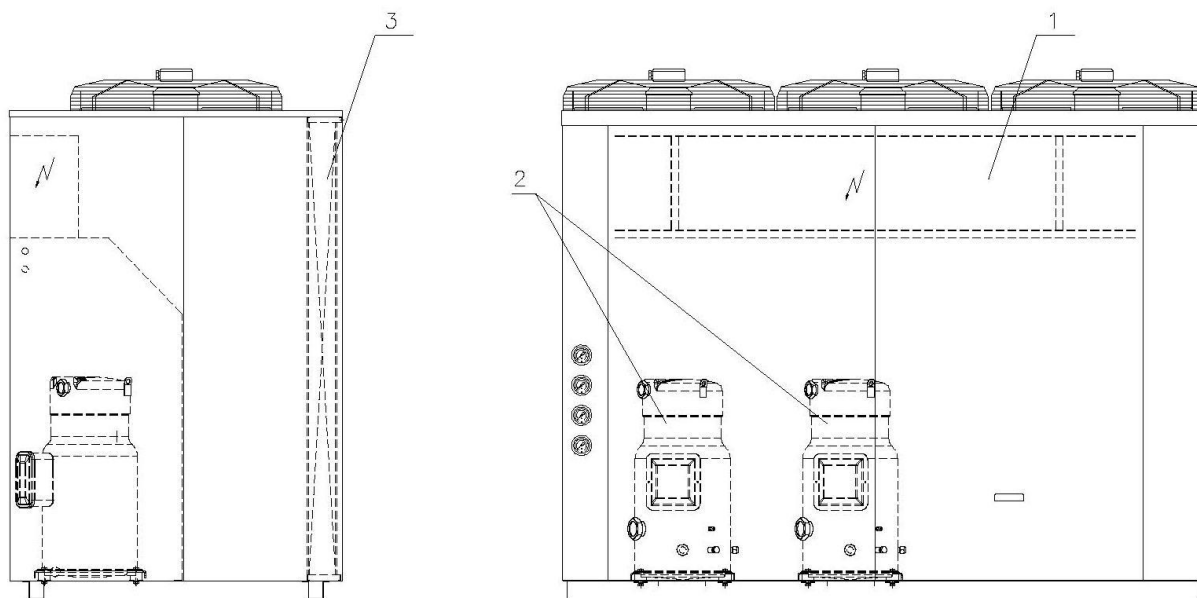

Picture 1

Condensing unit version MCE CENTRIFUGAL

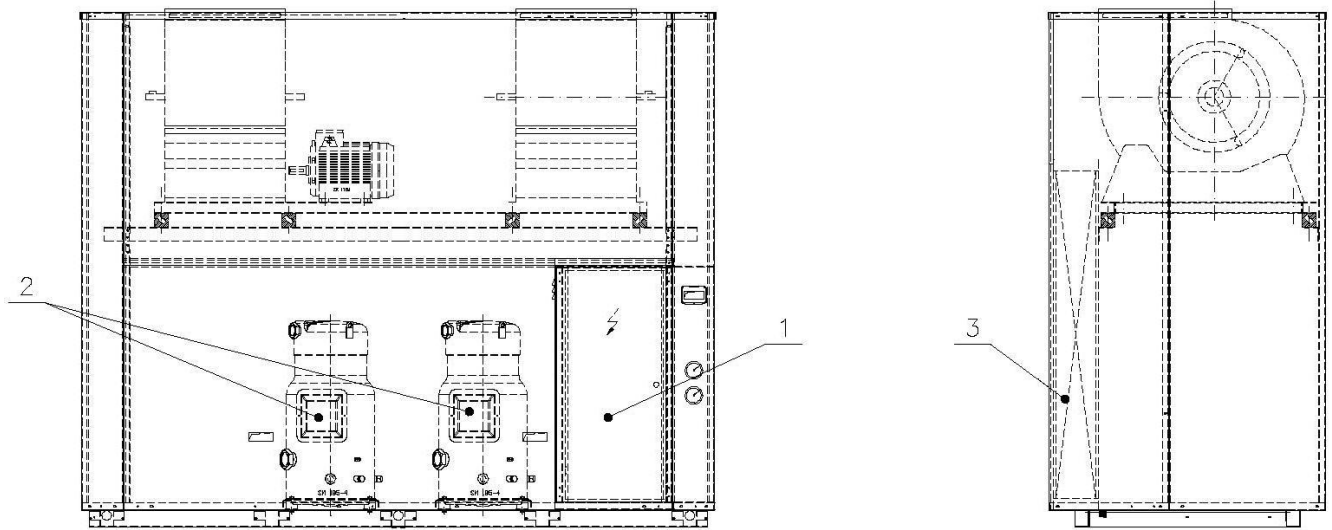

Picture 2

Condensing unit version MCH

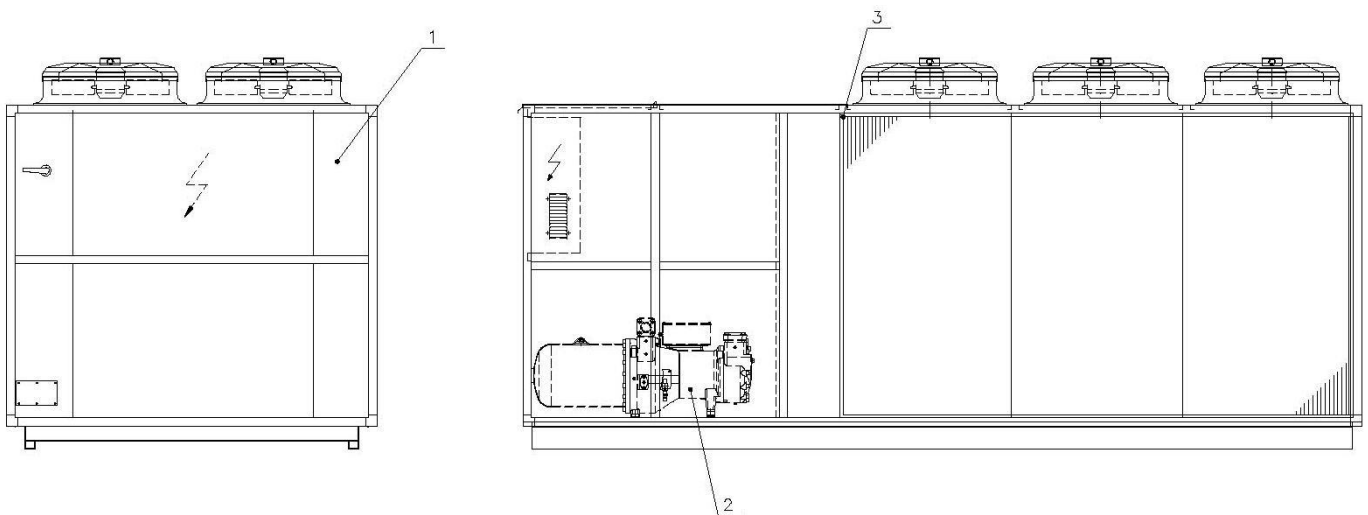

Picture 3

Key

- 1) Electric panel
- 2) Compressor
- 3) Heat exchange coil

3.3 Cooling circuit

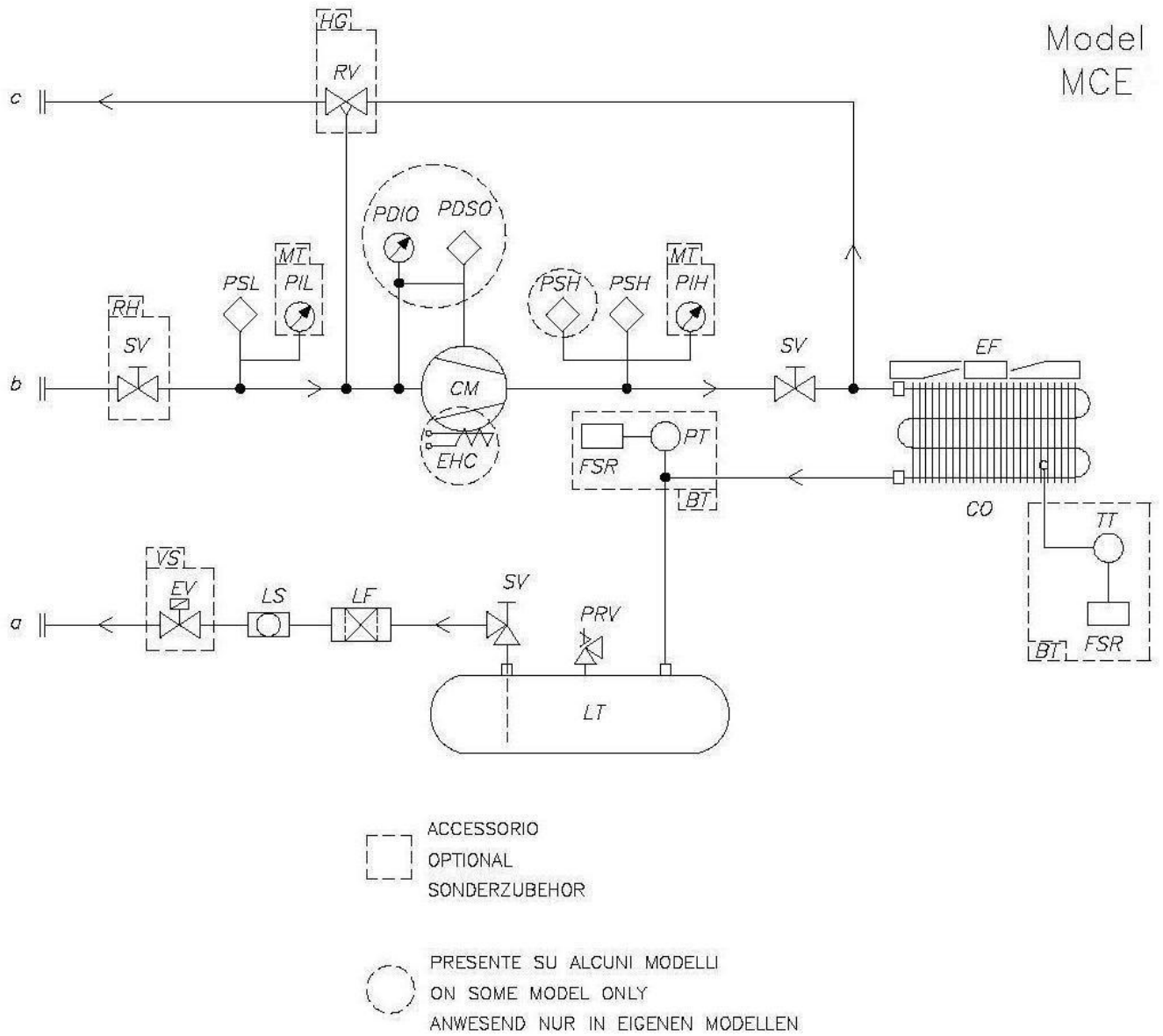

Picture 4

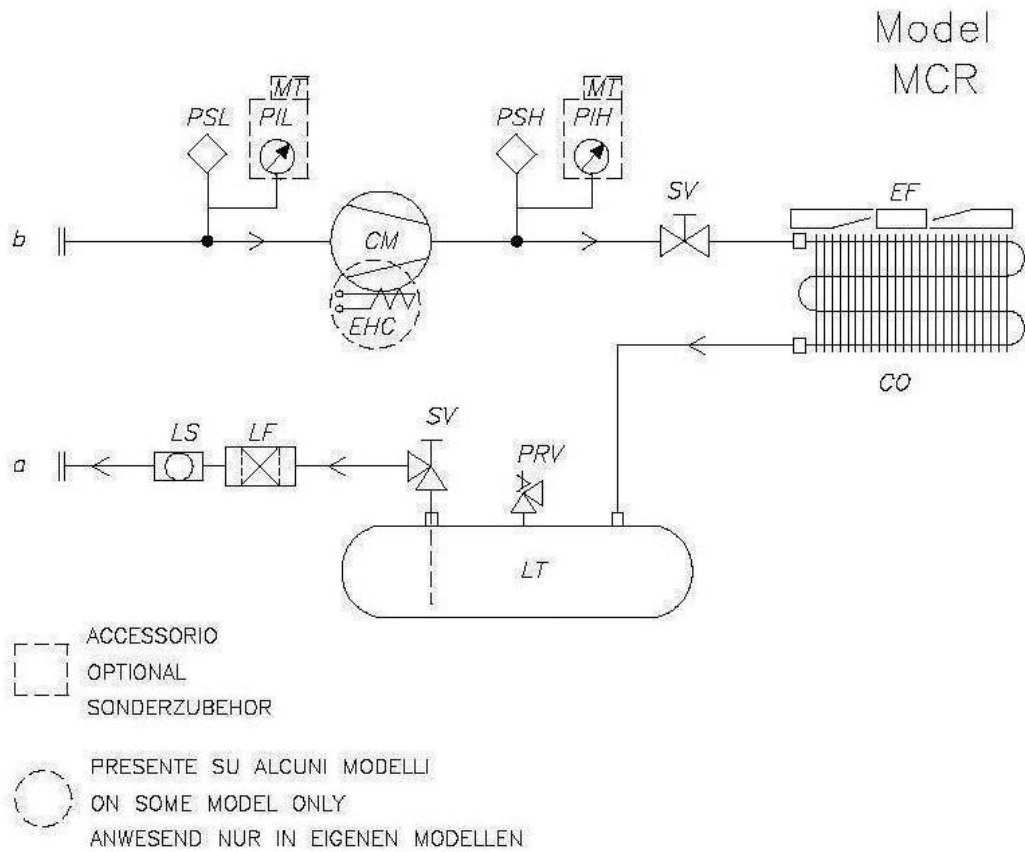

Picture 5

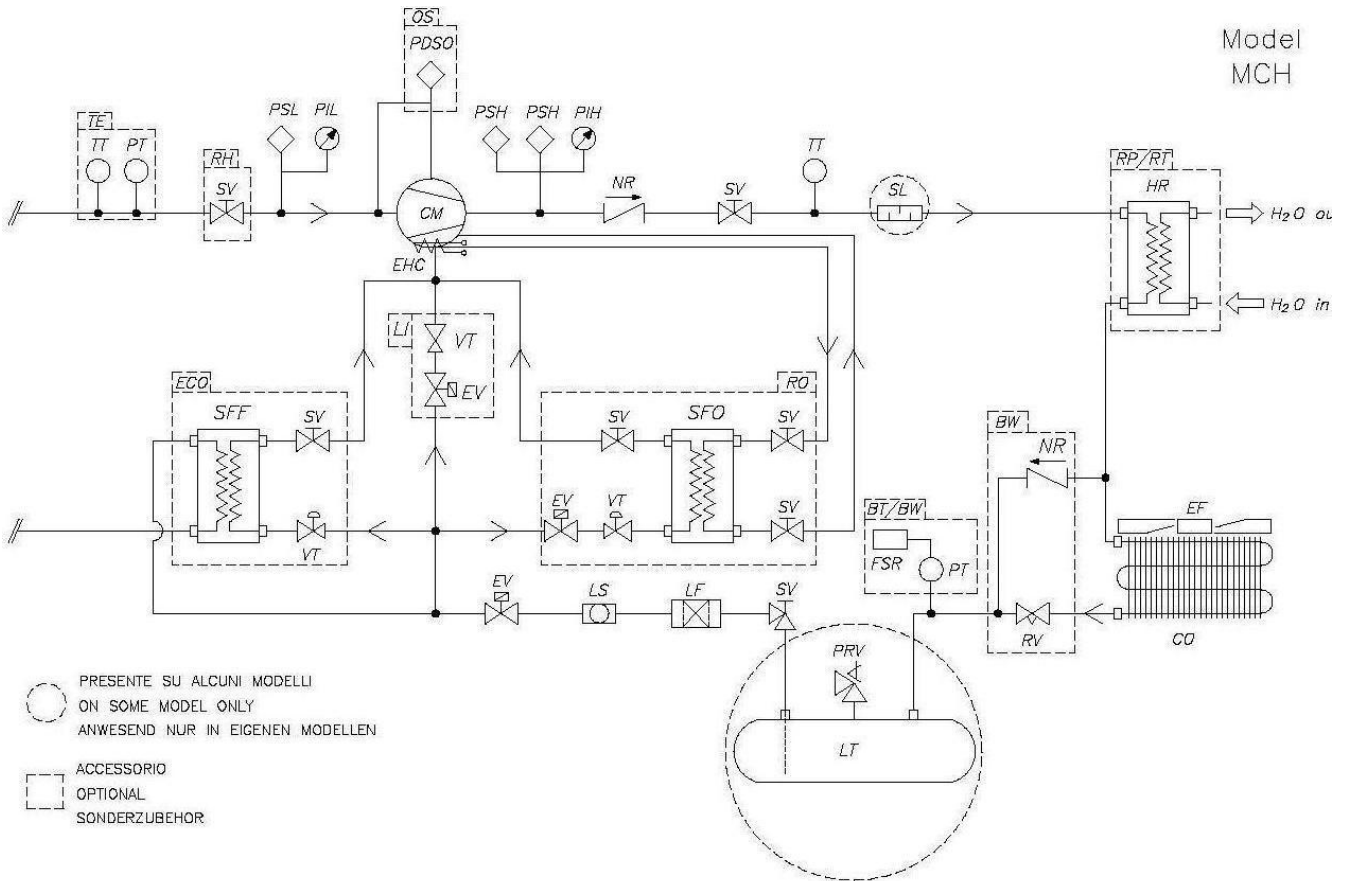

Picture 6

3.3.1 Cooling circuits key

AC	AIR HEAT EXCHANGER	PDIO	OIL GAUGE	VE	EXPANSION VESSEL
AD	AIR DISCHARGE VALVE	PDSO	OIL LEVEL PRESSOSTATIC VLAVE	VP	EVAPORATOR
AV	VIBRATION DAMPER	PDSW	DIFFERENTIAL WATER SWITCH	VT	THERMOSTATIC EXPANSION VALVE
CM	COMPRESSOR	PIH	HIGH PRESSURE GAUGE	WC	WATER COIL
CO	CONDENSER	PIL	LOW PRESSURE GAUGE	WD	WATER CHARGE AND DISCHARGE VALVE
CT	CONDUCTIVITY PROBE	PIW	WATER VALVE	WE	WATER EXCHANGER
EF	FAN	PRV	OVERPRESSURE DISCHARGE DEVICE	WF	WATER FILTER
EHA	ANTIFREEZE HEATER	PRW	SAFETY WATER FLOW SWITCH	WP	WATER PUMP
EHC	CRANKCASE HEATER	PSH	HIGH PRESSURE SWITCH	WT	WATER BUFFER TANK
EV	SOLENOID VALVE	PSL	LOW PRESSURE SWITCH	BG	HOT GAS COIL
FSR	FAN SPEED REGULATOR	PT	PRESSURE TRANSDUCER	YVCA	HUMIDIFIER FILL VALVE
FWV	4-WAY VALVE	RE	ELECTRIC HEATER	YVSA	HUMIDIFIER DRAIN VALVE
H	HUMIDIFIER	RV	MODULATING VALVE		
HR	HEAT RECOVERY	SA	LIQUID SEPARATOR		
HT	HUMIDITY PROBE	SFF	FREON – FREON HEAT EXCHANGER		
LF	DEHYDRATING FILTER	SFO	FREON – OIL HEAT EXCHANGER		
LS	SIGHT GLASS	SL	NOISE LEVEL REDUCER		
LT	LIQUID RECEIVER	SO	OIL SEPARATOR		
NR	NON-RETURN VALVE	SV	SHUT-OFF VALVE		
OF	OIL FILTER	TS	SAFETY THERMOSTATIC VALVE		
OLR	OIL LEVEL REGULATOR	TT	TEMPERATURE PROBE		
OT	OIL RESERVE	TWV	3-WAY VALVE		

3.4 Technical specification

The main technical features of the units are shown in the attachments.

3.5 Dimensional drawings

The drawing of the unit, here attached, shows the unit dimensions and the connections diameter.

3.6 Main accessories

1M: higher available pressure for fans

2M: higher available pressure for fans

A: Amperometer

AE: Power supply different from the nominal power.

BF: Operation at low external air temperatures (-20°C) with constant fan speed regulation by means of inverter

BFa: Operation at low external air temperatures (-20°C) with constant fan speed regulation by means of inverter (with option 1M)

BFb: Operation at low external air temperatures (-20°C) with constant fan speed regulation by means of inverter (with option 2M)

BT: Operation at low external air temperatures (-20°C) with constant fan speed regulation

BTa : Operation at low external air temperatures (-20°C) with constant fan speed regulation (with options 1M and 2M)
CF: Soundproofed compressors cabinet with standard material
CFU: Soundproofed compressors cabinet with lead material or similar
CI: Soundproofing jackets on compressors
CS: Compressor inrush counter
DS: Star/Delta compressors startup
GP: Protection grid for condensing coil
GP1: Protection grid for the technical section (compressors, pump group)
HG: Hot gas by-pass.
IG: Watch card
IH: Serial interface RS485.
IM: Seawood packing
LI: Liquid injection
MF: Phase monitor
MP: Oversized microprocessor
MT: High and low pressure gauges
M6: Modulating capacity control for 4-circuit units
M8: Modulating capacity control for 3-circuit units
M12: Modulating capacity control for 2-circuit units
M25: Modulating capacity control for 1-circuit units
OS: Safety oil flow switch
PA: Rubber vibration dampers
PM: Spring-type vibration dampers
PW: Part-winding compressors startup
PQ: Remote microprocessor
QR: El. Board on opposite side (available from model 842).
RF: Power factor correction system $\cos \varphi = 0,9$
RH: Shut-off valve on compressor suction side
RL: Compressors overload relays.
RM: Condensing coil with fins in marine alloy
RP: Partial heat recovery
RR: Condensing coil with copper/copper fins
RT: Total heat recovery.
RV: Personalised RAL paint
SC: Soundproofed compressors housing with standard material (already included in the Ultra-silenced versions)
V: Voltmeter.
VS: Solenoid valve.

4. INSTALLATION

4.1 Identification tag

The data for the identification of the unit are marked on a permanent tag (Picture 7).

EMICON AIR CONDITIONING AND INDUSTRIAL APPLICATION		TEL. ++39 0445 418811 FAX ++39 0445 418812 Via Orzogli 85-Padè (TN), 7	MADE IN EUROPE	CE
MODEL NUMBER	<input type="text"/>	MODEL NUMBER	<input type="text"/>	
NB 0407	SERIAL NUMBER	NUMBER OF PHASES	<input type="text"/>	
DRAWING NUMBER	Y-FH-Hz	VOLTAGE	<input type="text"/>	
REFRIGERANT TYPE	R	REFRIGERANT	<input type="text"/>	
WEIGHT (kg)	Kg	NET WEIGHT	<input type="text"/>	
WEIGHT (kg)	Kg	NET WEIGHT	<input type="text"/>	
MAX. PRESSURE (bar)	LP bar	MAX. PRESSURE (bar)	HP bar	
MAX. ALLOWABLE PRESSURE	<input type="text"/>	MAX. ALLOWABLE PRESSURE	<input type="text"/>	
MAX. VIBRATION	<input type="text"/>	MAX. VIBRATION	<input type="text"/>	

Picture 7 - Identification tag



The correct unit identification by means of the serial number is essential for the execution of any operation to carry out on the unit. The serial number must be always advised whenever submitting a request of technical service support.

4.2 Reception and inspection

It is very important to check the packing integrity immediately upon delivery. In case the packing is found damaged, it is necessary to accept the goods "with reservation" and indicate on the consignment note the state of the received goods and let the driver countersign it. Any claim concerning the delivered material must be sent to the manufacturer by fax or by registered letter within 8 days from the receiving date. It is advisable to unpack the unit only when the installation begins and possibly after the unit has been moved to the location where it must be installed.



It is forbidden to stack units, even if they are packed. If the unit is stored after receiving, it must be not exposed to weather agents, even if packed.

4.3 Handling

The handling of the unit must be carried out by expert personnel, equipped with appropriate equipment in relation to the weight and to the dimensions of the machine. During the handling operation, the machine must be always kept upright.



The weight of some models is unbalanced: check the unit stability before starting to handle it.

For any unit handling, please follow the instructions shown in Pictures 11, 12 and 13. In case the fork lift is employed, the forks must be spaced out to the maximum allowed by the pallet size. In case the machine is moved by means of a crane, it is important to avoid that cables and belts exert a too high tractive effort on the packing that might damage it.



Angle α must not be greater than 30° ; the pictures are just as an indication.



SCHEMA DI SOLLEVAMENTO

SCHEMA DE LEVAGE

LIFTING DIAGRAM

HEBESCHEMA

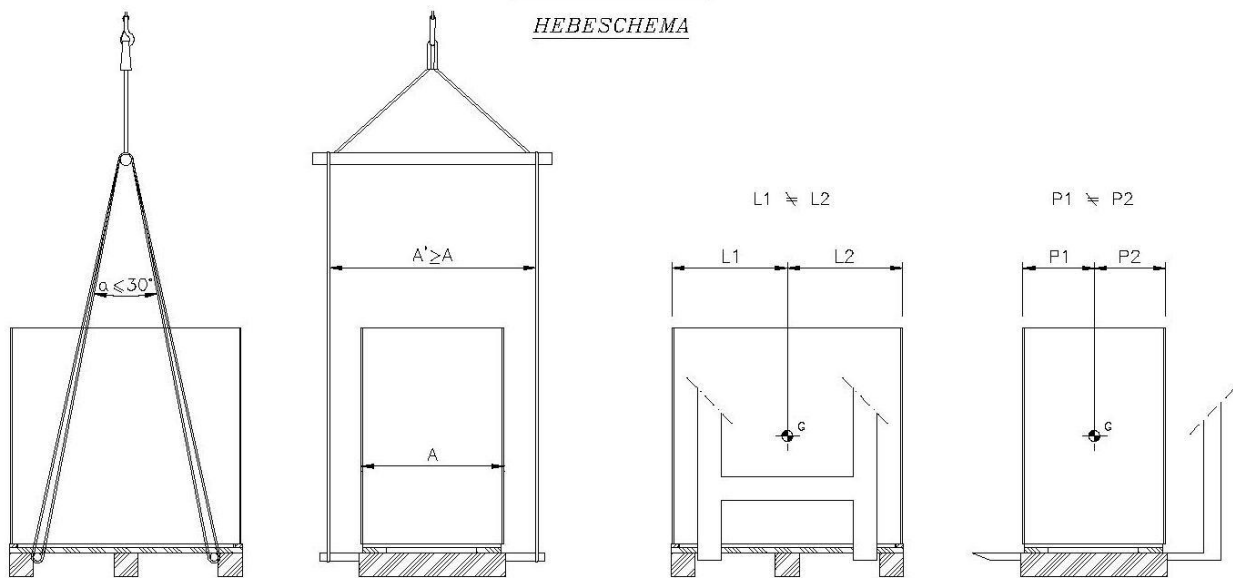

Pict. 8 - Lifting of MCE / MCR 41 - 822



SCHEMA DI SOLLEVAMENTO

SCHEMA DE LEVAGE

LIFTING DIAGRAM

HEBESCHEMA

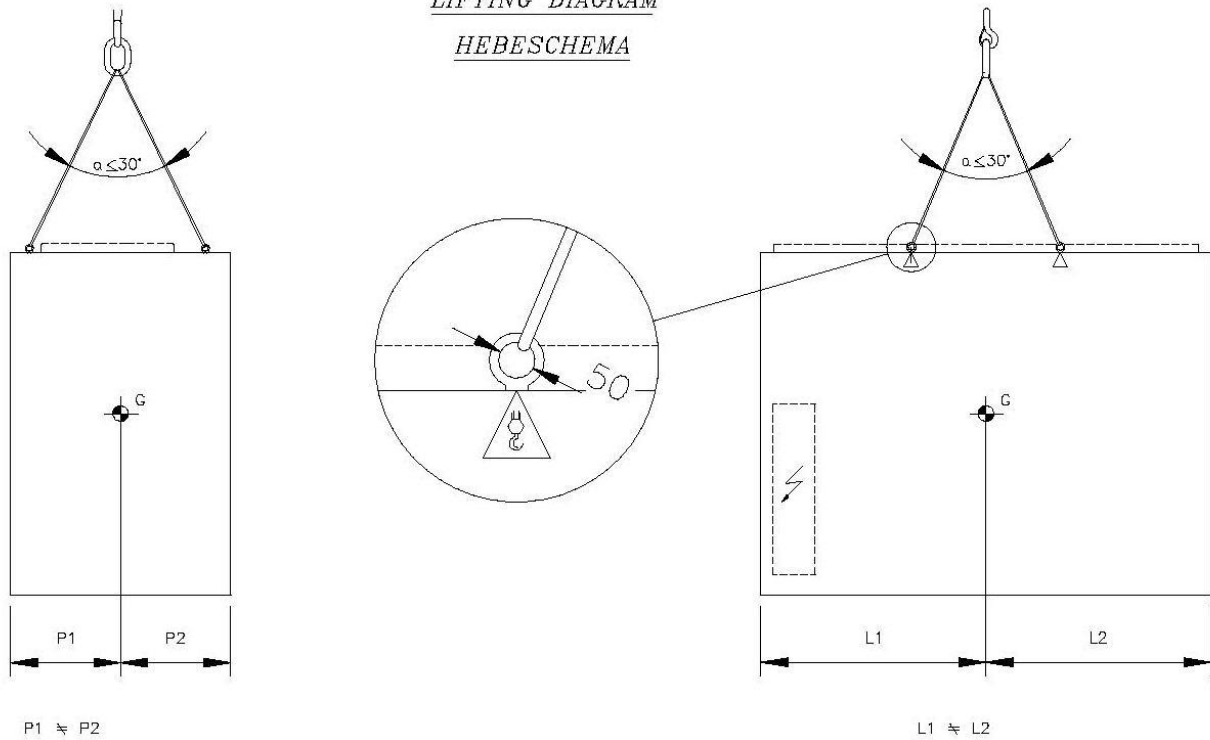

Picture 9 - Lifting of centrifugal units



SCHEMA DI SOLLEVAMENTO

SCHEMA DE LEVAGE

LIFTING DIAGRAM

HEBESCHEMA

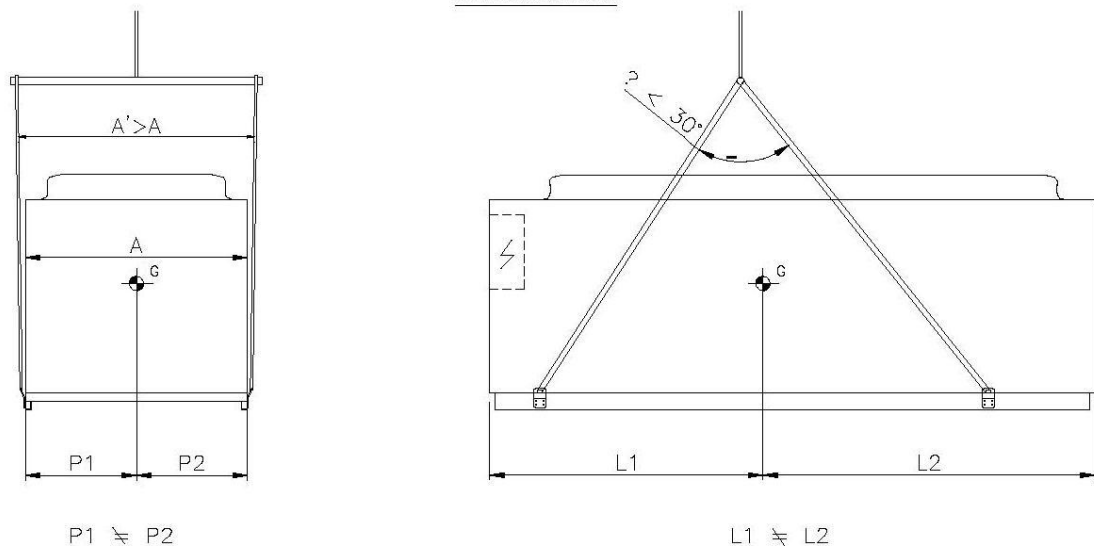

Picture 10 - Lifting of MCE 752 - 3172



SCHEMA DI SOLLEVAMENTO

SCHEMA DE LEVAGE

LIFTING DIAGRAM

HEBESCHEMA

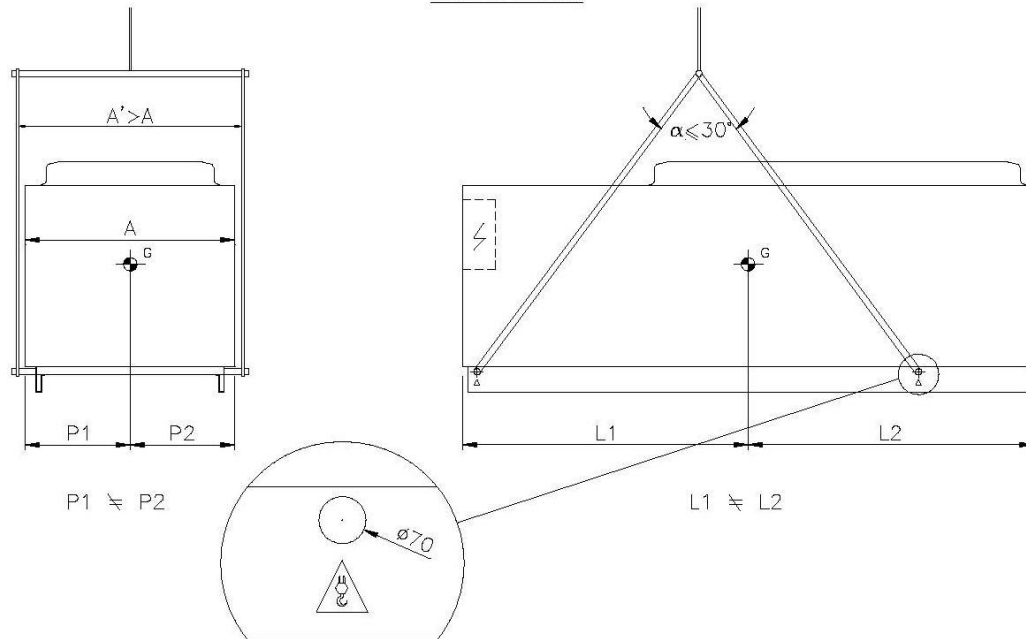

Picture 11 - Lifting of MCH 2102 - 8802



In case the manufacturer lifting kit (option) is not employed, make sure that the lifting equipment used, the cables and the belts are in compliance with the relevant local regulation.

The overall dimensions of the units, packaging included, are indicated in the packing list sent by e-mail in order to organise the loading.

4.4 Arrangements and placing

The installation of the machine is under the responsibility of the installer who must supervise the execution operations.

The execution of a correct installation presupposes that a plan has been drawn up by an expert and that is carried out by skilled and trained technicians.

In the following paragraphs there are some tips and information to keep in mind when planning and executing the machine installation.



The unit installation must comply with local existing laws.

Before placing the unit, the following points must be checked:

- Ø Connections for electric and hydraulic circuits must be done;
- Ø Enough room must be left around the unit to allow the routine and the special maintenance, such as compressors and heat exchangers replacement. The dimensions of this free space is represented by the dashed area as shown in Pictures from 12 to 19, for units with single and multi-scroll compressors and for units with screw compressors.
- Ø The floor where the machine is positioned can bear the total unit weight under normal operation

Picture 12 - Service Area for MCE / MCR 41 - 101

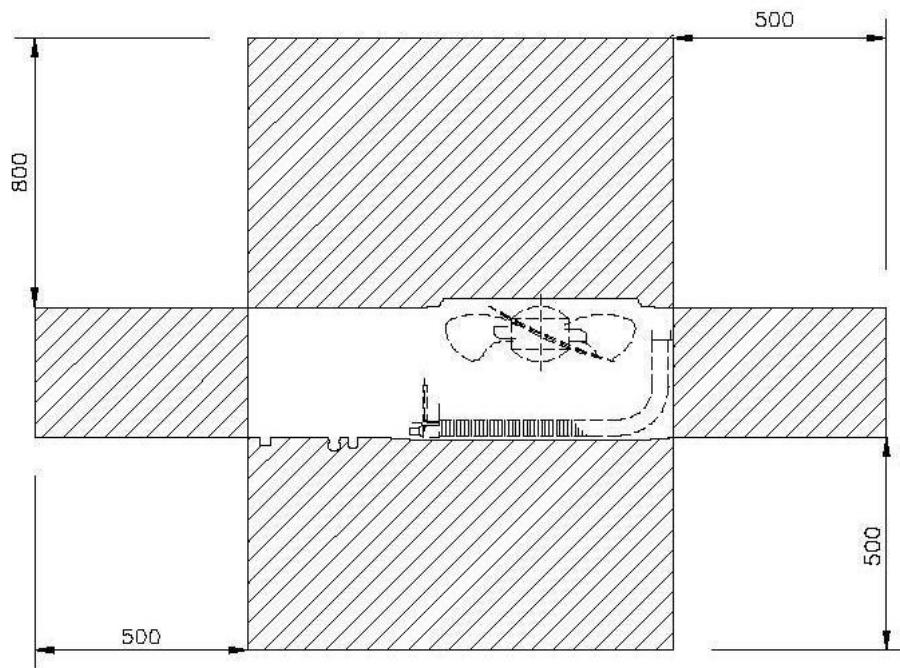

Picture 13 - Service Area for MCE 131 - 822 MCE version C 131 - 181

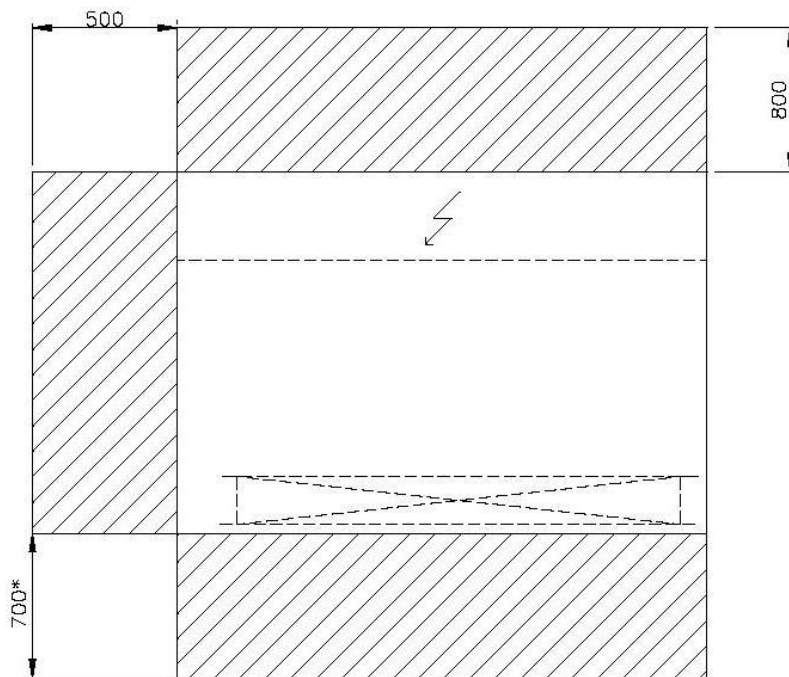

* SENZA CANALIZZAZIONE
SANS CANALISATION
WITHOUT CHANNEL
OHNE KANALISIERUNG

Pict. 14 - Service area version MCE 752 - 3172

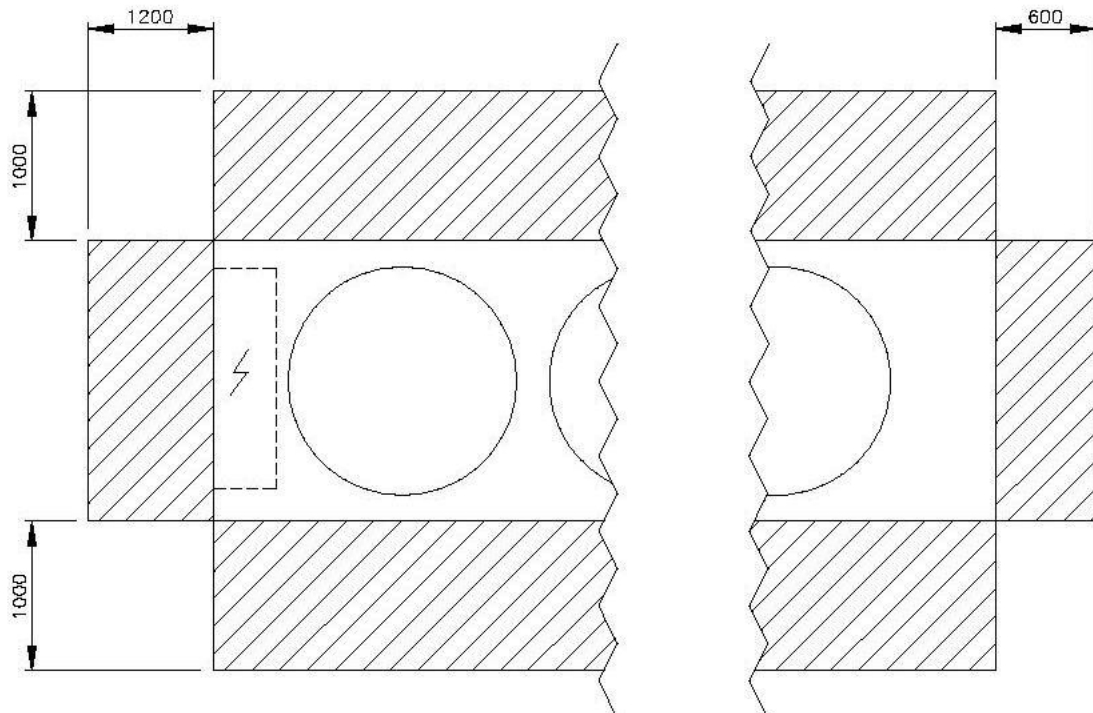

Pict. 15 - Service area version MCH TWIN 2102 - 8802

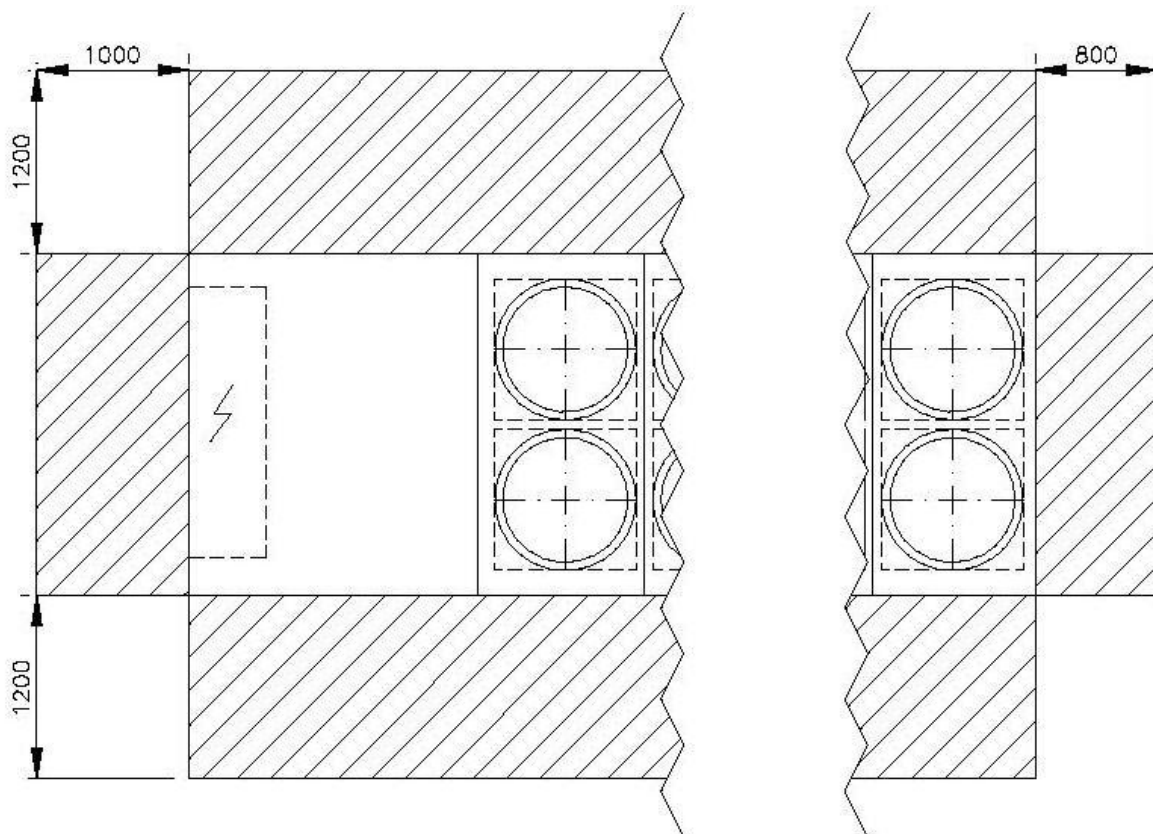

Pict. 16 - Service area version C MCE 201 - 822

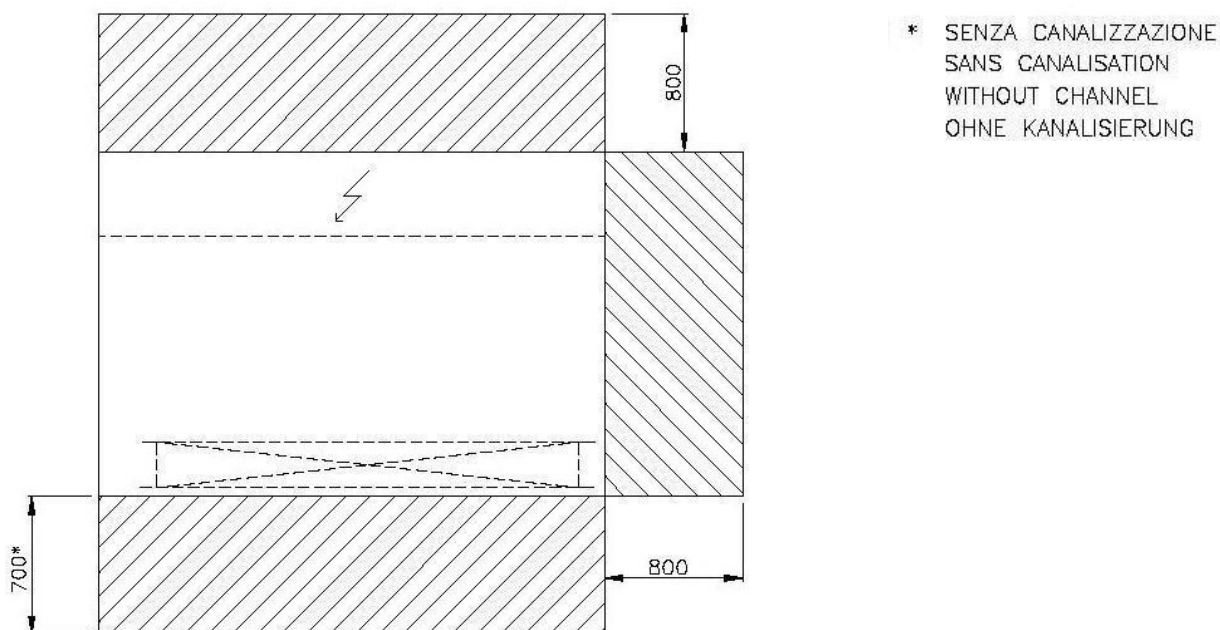

Pict. 17 - Service area version C MCE 842 - 2602

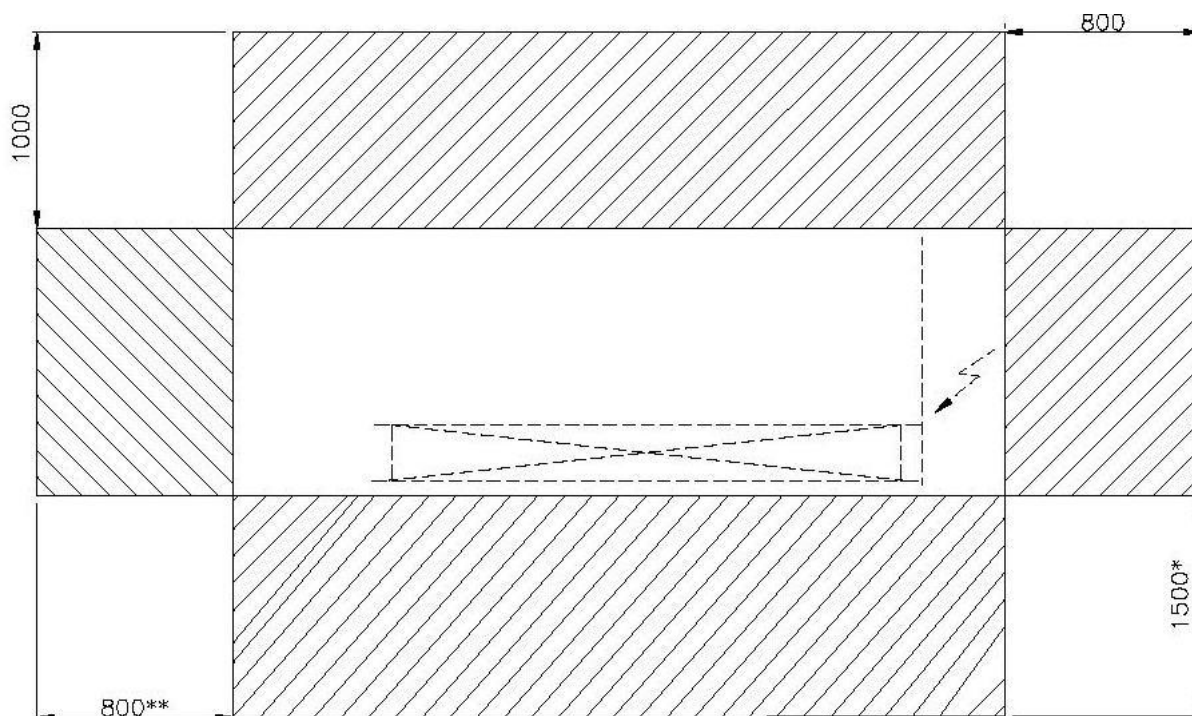

* SENZA CANALIZZAZIONE
SANS CANALISATION
WITHOUT CHANNEL
OHNE KANALISIERUNG

- ** E' NECESSARIO RISPETTARE QUESTA DISTANZA ANCHE PER IL COLLEGAMENTO IDRAULICO DEI MODELLI CON OPTIONAL RP.
- ** IL EST NECESSAIRE DE RESPECTER MEME CETTE DISTANCE POUR LA CONNECTION HIDRAULIQUE POUR LES MODELES AVEC LES OPTIONS RP
- ** IT IS NECESSARY TO SAFE THIS DISTANCE TOO, FOR THE HYDRAULIC CONNECTION USING THE MODELS WITH OPTIONAL RP.
- ** BEI MODELLEN MIT OPTION RP MÜSSEN FÜR DEN HIDRAULIK ANSCHLUSS AUCH DIESE ABSTANDE EINGEHALTEN WERDEN.

Picture 18 - Distances in case of coverings

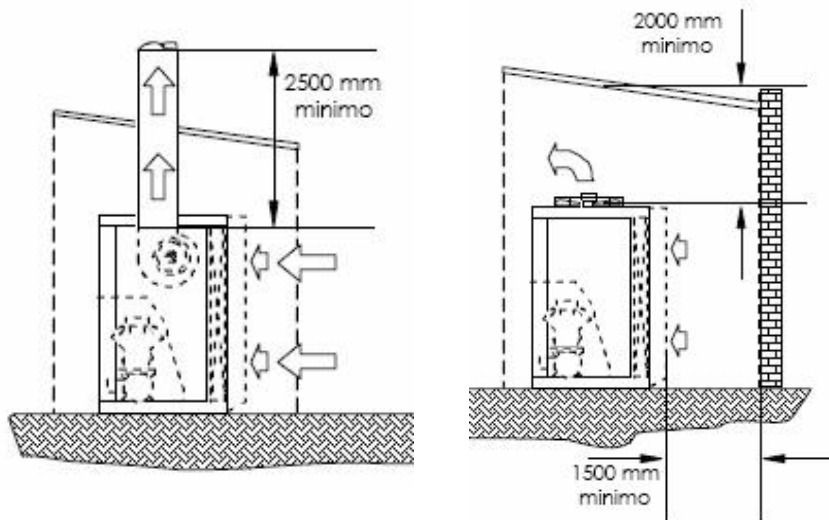

Before starting to handle the unit to position it, it is necessary to identify the best way to arrive to the place, taking into consideration the unit overall dimensions and weight, the available lifting equipment and any optional accessory dimensions. All units described in this manual do not need any special foundation, since they can be simply laid down on the chosen surface, just placing rubber gaskets or spring-type vibration dampers (options) underneath. Make sure that the unit features indicated in the attached technical data sheets match those required for the undertaken project.

4.5 Cooling connections

These units are supplied with nitrogen charge (20 bar). Discharge pressure carefully only before carrying out the cooling connections. Copper pipes must be employed for the connections to their ventilated condenser units which are installed outdoor. Only expert refrigeration technicians are allowed to perform the hydraulic connections and in conformity with local regulations. The following general instructions must be followed:



Even if refrigerant is not classified as a toxic substance, pay the maximum attention during the refrigerant charge operation and strictly follow the security requirements in compliance with law by decree 81/08; in particular, the appropriate and necessary equipment must be worn to avoid contact, inhalation and ingestion.

If any of the above mentioned cases occurs, it is advisable to consult the security specifications for the operations of first aid and emergencies concerning the employed refrigerant.

In case it is necessary to go to the doctor, it is advisable to bring these refrigerant security specifications with you.

The pipe installation must be performed by a skilled refrigeration technician.

The piping path must be as shortest as possible in order to reduce the quantity of refrigerant gas and oil circulating and to reduce the pressure drop. If copper pipes have to cross electric wires, it is advisable to isolate the tubes in order to avoid the danger of inducted current. Lines must be realised with copper tubes, specifically conceived for cooling systems and they must have an appropriate diameter, as shown in the attached drawing.

It is here reminded that the total piping length is the result of its geometrical calculation plus the length of valves, bents and fittings present on the line itself. If failing to have more accurate information, you can obtain the total length by multiplying the geometrical length of the line by 1,5 or 2.

Copper pipes must be adequately supported by brackets so as to make them secure and fasten, and at the same time allow thermal expansion of the copper tubes.

If the discharge pipes go through rooms where people normally live, it is advisable to install rubber vibration dampers and a sound attenuator as nearest as possible to the compressor

The piping insulation, except for special requirements, can be applied on the following parts only:

- Ø Suction pipes ;
- Ø Discharge pipes, where pipes can be accessible to unauthorized people so that any damage or skin burn can be avoided.

During the piping installation, the refrigerant tubes must be sealed to prevent humidity and dirt go inside. The piping arrangement must consider easy access for operations like bracket insertion, tube welding and inspection.

Once pipes are placed, before carrying out the connections to the unit, the system must be leak tested by means of pressurized nitrogen. It is recommended to mark the pressure test value on a pressure gauge.



Do not exceed 20 bar when pressing with nitrogen.

The nitrogen also enables the circuit to dry up. If the circuit pressure drops, this means that the circuit is not sealed off. It is, then, necessary to let in a small quantity of refrigerant so that it is possible to locate any leak by means of appropriate detectors. If a leak is detected, after the repair, a new leak test must be carried out again.

Finally, the vacuum and the charge of the system can be executed following the instructions as described in par. 4.6

4.6 Vacuum and charge execution of the system

4.6.1 General warnings

For a correct and reliable operation of the system, once the connection lines between the indoor and the outdoor units are carried out, it is extremely important to clear the circuit of any air, humidity, non-condensable gas and, in general, of any polluting substance presence before executing the refrigerant charge. The presence of solid particles like metal dust, welding debris and dirt of small dimensions that cannot be detected by the mechanical filters can cause serious damages to the surfaces in movement and involve a reduction in efficiency and of compressor life



Do not perform any holes in the cooling circuit, the complete rescue of metal particles produced would be then prevented

If excessive humidity persists inside the cooling circuit, negative consequences can arise. Humidity can freeze inside the thermostatic valve and can even clog it up, causing the unit stop because of the low-pressure alarm. A significant amount of humidity can saturate the filter drier in a very short time and it will be necessary to replace it (with consequent operating interruption of the system). Humidity chemically interacts with the refrigerants and especially with polyester lubricant oils (normally employed with refrigerant type R407C, R134a, R404A, etc.). This interaction creates acid substances that, if present in fair amount, can damage the compressor electric motor insulation provoking motor burns and rusted copper pipes that can generate solid impurity.



Reduce as least as possible the exposure of the circuit and its part to the atmosphere, especially if compressors are charged with polyester oil.

If non-condensable gases are not eliminated accurately from the circuit, they can gather inside the condenser and the liquid receiver. If gases are in the condenser, they can cause a reduction of the useful thermal exchange surface, meaning a condensing temperature increase and, consequently, a reduction of the energy efficiency and of the system reliability. In worst cases, the unit can be stopped by the activation of the high-pressure switch. Big amounts of non-condensable gases gathered in the liquid receiver can cause the malfunctioning of the thermostatic valve, in case a mixture of refrigerant and non-condensable vapor replaces liquid refrigerant. If this happen, there will be a strong reduction of the evaporating temperature up to the activation of the low-pressure switch, in worst cases, thus involving a reduction of the unit cooling capacity and a reduction of the system efficiency and life



Picture 19



Picture 20

4.6.2 Vacuum execution

Once the cooling lines are completed and checked that no leaks are present, the vacuum must be executed as described here below (see Par. 4.5).



The indoor unit is normally leak tested by the manufacturer by cooling circuit pressurization



The unit is supplied with nitrogen pressure (20 bar). Therefore, if during the installation it results that the cooling circuit is not pressurized, this means that there is a leak. It is necessary to detect it and repair it before going on with the installation operations.



Before starting the circuit vacuum operation, make sure all nitrogen contained in the liquid receiver has been discharged.

a) Connect a vacuum pump (a two-stage pump able to keep a pressure of 0,04 mbar - Picture 19) to the system employing the charge connections present on suction (Picture 20) and on liquid lines. The vacuum pump must have a suitable water flow capacity for the circuit size.



Do not use the compressor for carrying out the vacuum inside the cooling circuit.



Make sure all valves are open in order to avoid that some circuit parts result cut off.

b) Let the vacuum pump work until the pressure shown on the appropriate vacuum meter (Picture 19) does not go below 10 mbar.

c) Isolate the pump from the circuit by means of the appropriate cut-off valves and wait for 30 min.

d) If pressure goes on increasing during the pump stop period or if it is impossible to reach the desired pressure value, it means there is a leak in the circuit. It is necessary to detect and repair the leak, and after that, a new procedure must be performed again starting from step b).

e) If pressure goes up until it reaches a climax value, it means the circuit contains a big amount of humidity. In this case, it is necessary to let in nitrogen in the circuit (up to about 2 bar) and then repeat steps b), c) and e) for at least twice, then proceed with step f).

f) If pressure stabilizes after a short increase, it means the circuit is leak proof and reasonably dried. Start up again the pump after the shut-off valves are open and let it operate for 2-4 hours according to the circuit size after pressure has returned below 10 mbar.



Do not operate the compressor nor employ a megahom meter while the circuit is vacuum

4.6.3 Refrigerant charge execution

Once vacuum is completed, the circuit must be charged with the exact quantity of refrigerant and, if necessary, of anti-freeze oil.



Avoid any refrigerant gas release in the environment during the charge operations.

a) Connect a full up refrigerant gas cylinder to the circuit employing the charge connections present on the liquid line.



Make sure the refrigerant you are going to use for the circuit charge is the same as shown in the unit identification tag. In case of discrepancies, contact the manufacturer.

b) Open the cylinder valve and charge the refrigerant until the circuit pressure reaches the same pressure as in the cylinder (if needed, repeat the operation with additional gas cylinders).



If the refrigerant is a mixture compounds, make sure to let enter the circuit in a liquid state in order to avoid compounds separation. On this purpose, cylinders are provided with two distinct valves: one for the vapor and one for the liquid.

c) Shut off the cylinder valve, disconnect it from the liquid line and connect it to the suction line (possibly prior to the evaporator).

d) Start up the unit, open the cylinder liquid valve and complete the charge (if needed, use more cylinders) until the sight glass located immediately after the filter drier becomes clear and does not present foam or gas bubbles during the operation in nominal conditions.

In order to facilitate the charge operation, the following tables show, as an indication, the necessary amount of refrigerant to charge the different types of indoor units and the corresponding connecting pipes. For a correct calculation of the refrigerant quantity, it must be also taken into account the volume of the outdoor unit cooling circuit and of any other component installed (such as additional liquid receivers, oil separators, etc.). In case the cooling lines are very long or in case oil separators are installed on the compressors discharge, a fair quantity of anti-freeze oil must be added



Check if the employed oil is compatible with the one charged in the compressor (check it out in the compressor's identification tag).

In case oil separators are employed, add the lubricant quantity suggested by the manufacturer.

If cooling lines are longer than 30 m, charge about 0,2 kg of oil every 10 m of piping (beyond 30 m). In any case, check the correct oil charge by checking the oil level through the compressor sight glass after about 30 minutes of standard operation mode.



An overload oil charge can lead to a system efficiency drop and to compressor breaking

4.7 Electric connections

Check the electric circuits have not been damaged during transportation. Check all terminals screws are tight. Make sure the power tension and frequency match the same data as specified on the unit identification tag.



Before starting the electric connection, it is advisable to check the wiring diagram contained in the unit electric panel.

4.7.1 Power supply connection

The unit can be powered with a 5-pole cable (3 poles+N+ T), if the power supply tension is 400V/3F/50Hz. In case the power supply tension is 230V/3F/50Hz, the supply cable is a 3-pole cable. On demand, it is possible to supply units with arrangements for special power supply tension (check the identification tag and the wiring diagram).

Connect the phases and the neutral to the terminals of the main switch and the earth wire to its corresponding terminal. Use a power supply cable of adequate cross section and of moderate length to avoid voltage drops.

Protect the power supply cable by means of an automatic switch of appropriate size and features.



For the cross section of the power supply cable, the size of the automatic switch and the characteristics of the electric components, check the wiring diagram attached to the present manual.

4.7.2 Warning in case of connection to the terminal board when optional "TE" is installed

In case the unit connected to the condensing unit is provided with optional TE (electronic thermostatic valve), check the presence of pressure switches on the cooling circuit.

4.7.3 User's terminal board connection

A user terminal board (Picture 22) is available with free contacts designed for:

Ø Generic alarm state (1);

Ø Unit remote ON/OFF (2).

Check the wiring diagram for the exact correspondence of the terminals numbers

Picture 21

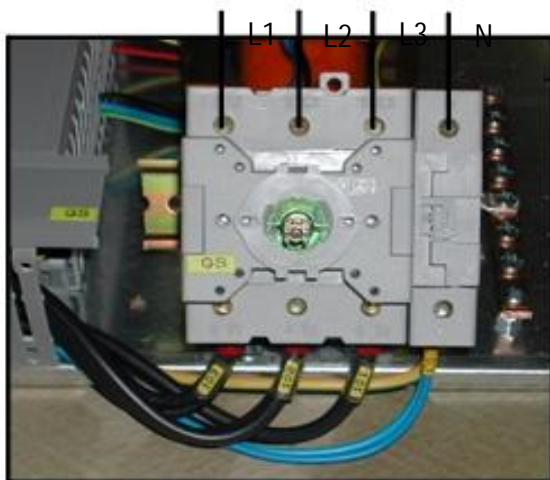

Picture 22



U2: open contact
UNIT OFF
30: closed contact
UNIT ON

U9: usually open
U10: common
U11: usually closed

4.7.4 Instructions for the electric connection

The electric connection must be carried out by skilled personnel. The power cable input is shown in the attached dimensional scheme.

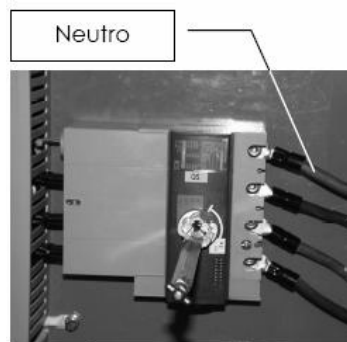

Picture 23

The power cable conductors must be connected to the free terminals upstream the main disconnecting switch, while the grounding conductor must be connected to the appropriate terminal PE or to the ground bar. On the lateral side of the unit, a hole must be performed to introduce the electric power cable and to arrange its corresponding cable connection.

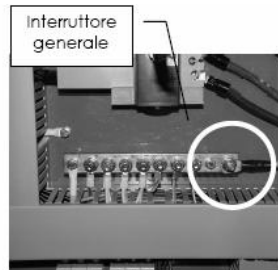

Picture 24

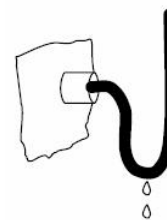

Picture 25



If the power cable comes from the top wiring box, perform a bend on the cable (Picture 25) before plugging it into the cable connection as illustrated in the example on the top on the right.

If the water circulating pump is not controlled by the unit microprocessor, it is recommended to connect an auxiliary contact of the pump electromagnetic switch to the remote ON/OFF terminals preset in the electrical panel (see attached wiring diagram), so that the unit can start only when the pump is working.

On its cover, the electrical board has the programming panel of the unit microprocessor. For the controls management, its functions and for the microprocessor use, see Chapter 8 "Unit control and start-up" of the present manual.

Picture 26

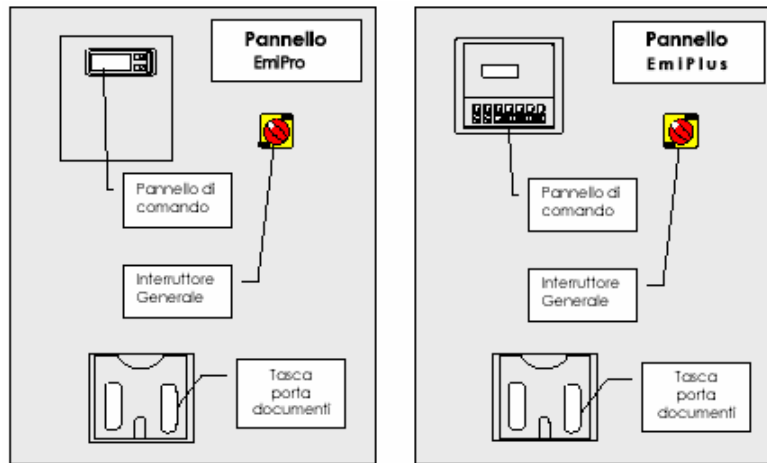

4.7.5 Phases sequence in the power supply line

The rotation direction of all electric motors installed on the unit (compressors, fans, pumps) are checked and harmonized during the operational test performed by the manufacturer (at the exception of units supplied with arrangements for special power supply tension). In case of three-phase power supply, when connecting the unit to the power supply, it is necessary to check that the phases are connected in the correct sequence. On this purpose, make sure that all electric motors rotation is right: for pumps and fans, refer to the information indicated on the component itself; for scroll compressors, follow the instructions as described at Par. 5.1.

If the rotation of any component is wrong, two out of three phases must be inverted in the terminals of the main switch (do not unplug the neutral). If some components go on rotating in the wrong direction, check the conductors sequence of each 3-phase component and correct it, if needed.

5. OPERATION

5.1 First check

Before starting the unit, make sure that:

- Ø All security conditions are respected;
- Ø The unit is placed correctly on the floor;
- Ø The service area is respected;
- Ø The electric connections are performed correctly;
- Ø The electric tension ranges within a tolerance of 10% compared to the unit nominal tension;
- Ø The connection to ground is performed correctly;
- Ø All electric and hydraulic connections are tight properly.

If a 3-phase scroll compressor is installed on the unit, when starting, check the rotation is correct. If the compressor rotates in the opposite direction, it produces a higher noise level, it causes a pressure difference between discharge and suction and its electric absorption is lower than scheduled; after few minutes of operation with the reversed rotation, the internal heat protection can be enabled. If necessary, reset the correct rotation direction by inverting two out of three phases in the input terminals of the main switch.

5.2 First startup

The first startup must be performed by a skilled refrigeration technician. The oil heaters must be energized for at least 3 hours before the unit startup, and for 6 hours in case of screw compressors. Check the shut-off valves on compressor and on the cooling circuit are open. Make sure all points described in the previous paragraph have been checked.

To start the unit:

- Ø Turn the main switch to "ON" position.
- Ø Press the ON/OFF button on the microprocessor keyboard.



Compressors startup time-delay has a default value equal to 1 minute and it can be re-set. Check all safety and control devices are working properly.

To stop the unit:

- Ø Press the ON/OFF button on the microprocessor keyboard;
- Ø If the unit must not work for more than 24 hours, turn the main switch to OFF position.

5.3 Microprocessor setting

Make sure the desired parameters are set on the microprocessor.

If the preset parameters need to be changed, proceed as described in the microprocessor manual (here attached).

The standard units are designed to work with an outlet cooled water temperature higher than 5°C; for operation at lower temperatures, use anti-freezing solutions having adequate properties. If necessary, set the anti-freeze set point.

5.4 Fault alarm and display system

The troubleshooting is realized by the microprocessor, which activates an alarm and shows on its display the type of fault occurred (see also the attached microprocessor manual). Since the alarm state is very often generated by an unfitted electric contact, in case of fault make sure all wiring connections are plugged in the corresponding terminals. In case of fault, consult the attached microprocessor manual to check the parameters setting has been done properly

5.5 Troubleshooting

TROUBLE	POSSIBLE CAUSE	CORRECTIVE ACTION
A) The unit does not work	The electric panel is not powered or the contact is open	Check the tension and close the contacts
	The external impulses fail	Check the operation of the flow switch. Vent the system and check more external impulses
	Compressor delay timer	Wait for the set time
	Lack of impulse from the service thermostat	System in temperature, lack of demand; check the setting and the operation
	Lack of impulse from the antifreeze thermostat	Check the setting and the operation
	Intervention of the fans' thermal relais	See point F
	Lack of impulse from a safety device	See point D - E
B) Compressor does not start	Burnt or seized compressor	Replace compressor
	De-excited compressor switch	Check the tension at compressor coil's heads and the continuity of the coil itself
	Power circuit open	Search the cause of protection intervention; close compressor automatic switch

TROUBLE	POSSIBLE CAUSE	CORRECTIVE ACTION
C) the compressor does not start due to the intervention of the max pressure switch	Pressure switch failure	Check and replace
	Exceeding refrigerant charge	Recover exceeding gas
	Air Condenser obstructed. Lacking airflow	Clean with compressed air
	Condenser fans failure	See point F
	Condenser fans rotating in opposite direction	See paragraph "electric connections"
D) the compressor does not start due to the intervention of the min pressure switch D1) compressor starts and stops again and again	Presence of un-condensable gas in the refr. circuit	Charge the circuit after discharging it and vacuum
	Pressure switch failure	Check and replace
	Unit totally discharged	See point G
	Clogged filter	Check and replace
	Shut off valve on liquid line not completely open	Check and open completely
	Thermostatic expansion valve does not run properly	Check, clean or replace
	Ice on evaporating coil	See point L
F) fans do not run	Ice on evaporator	Check thermostat and thermostatic valve
	De-excited electromagnetic switch of fans motors	Check the tension at electromagnetic switch coil's heads and the continuity of the coil itself
	Intervention of fans motors thermal relais	Check insulation between windings and between them and earth
G) Lack of gas	Not set or damaged speed regulator	Check the setting of the regulator or replace it
	Leakage in the refr. circuit	Check the refr. circuit with a leak detector after putting the circuit under pressure at approx 4 bar. Repair, make the vacuum, and charge
H) unit runs always without stopping	Lack of refrigerant gas	See point G
	Wrong setting of the operating thermostat	Check setting and replace
	Exceed thermal load	Reduce thermal load
	Compressor does not give expected cooling capacity	Check, replace or review
	Obstructed liquid filter	Clean or replace
I) unit runs properly but with insufficient capacity	Thermostatic expansion valve not properly operating	Check, clean or replace
	Poor refrigerant charge	See point G
	Humidity in the refr. circuit	Replace filter and dry and charge circuit

5.6 Routine maintenance

5.6.1 Type and frequency of periodical checks



Before accessing any component inside the unit, turn the main switch of the power supply to OFF position. Then, also turn the unit main switch to OFF position.



Only trained technicians are allowed to perform operations with powered electrical panel and with open panel board, since some functions of the system fail.

It is recommended to carry out periodical checks in order to make sure the unit works properly. Only authorized and skilled technicians are allowed to perform this kind of operations, included any maintenance operation.

5.6.2 Operations on the cooling circuit

Every time an operation involves the cooling circuit discharge, the gas must be collected by means of the appropriate gas recovery for environmental safety reasons.

Once the repair on the cooling circuit is performed, carry out the following operations:

- Ø Leak detection;
- Ø Vacuum and dehydration;
- Ø Refrigerant charge.

A) LEAK DETECTION

Charge the cooling circuit with the gaseous refrigerant up to reach a pressure of 1 bar. Then, add anhydrous nitrogen by means of cylinders with reducer up to reach a pressure of 15 bar.

Look for possible leakage and, if present, discharge the cooling circuit before welding (with phosphorus copper alloy with a minimum of 2% of silver).



Discharge completely the cooling circuit before welding in order to avoid explosions.



Do not use oxygen instead of nitrogen in order to avoid explosions.

B) VACUUM AND DEHYDRATATION

To obtain a good level of vacuum, an appropriate pump must be used (1,4 mbar of absolute pressure, 30 l/min. of water capacity). If the circuit has been open only for short time, by using this pump, only one vacuum operation is usually enough to reach the absolute pressure 1,4 mbar. If such a vacuum pump is not available or if the circuit has been open for long time, it is highly recommended to perform the vacuum three times by breaking the vacuum by means of the refrigerant. This method is also suitable when there is a high quantity of moisture in the circuit. The vacuum pump must be connected to the charge connections on high and low pressure side of the circuit.

Follow this procedure:

- Ø Discharge the circuit up to an absolute pressure of 35 mbar, then charge the cooling circuit with refrigerant gas up to reach a pressure of about 1 bar;
- Ø Repeat again the operation as described above reaching an absolute pressure of 35 mbar;
- Ø Repeat the above operation for the third time reaching the minimum absolute pressure as possible.

This operation allows to remove up to 99% of the polluting substances.

C) REFRIGERANT CHARGE

Follow this procedure:

- Ø Connect the refrigerant gas cylinder to the male charge connection 1/4" SAE placed on the liquid line, letting some gas go out to remove the air in the connection pipe;
- Ø Turn the cylinder upside down and charge the liquid up to reach 75% of the total charge;
- Ø Now connect to the charge connection on the suction line and, keeping the cylinder upright, complete the charge till the temperature of the liquid pipe before the filter is lower than 7-8°C for the chiller (4°C for the heat pump) compared to the temperature shown on the refrigerant manometer for the discharge pipe.

5.7 Precautionary planned maintenance

List of operations

	Every 6 months	Every year
Check of cooling lines and of their insulation		X
Compressor noise level check	X	
Electric connection tightening check	X	
Contactors status check	X	
Check of conductors insulation status		X
Liquid sight glass check	X	
Electric absorption check	X	
Working pressures check	X	
Unit general conditions check		X
Probes setting check	X	
Set parameters check		X
Refrigerant filter pressure drop check		X
Safety valve check		X
Safety pressure switch check	X	
Electric protections check	X	
Check of air presence in the hydraulic circuit	X	
Check of condenser cleaning condition		X

5.7.1 Coils cleaning (on the floor and under coverings)

Use a stiff-bristle brush and the necessary equipment; the use of an industrial vacuum cleaner may facilitate this operation.

- a. Disconnect the unit from the power supply by opening the main switch,
- b. Remove the protection grid from the coil (if present),
- c. Brush the coil from the top to the bottom, being careful not to damage the fins.
- d. Accompany the brushing with the hoovering.
- e. Remove the dust and the down gathered.



Do not use compressed air (it might damage the fins) or water (it might cause scale).

5.7.2 Check of lubricant leaks - lubrication oil pressure

A lubricant oil leak in a cooling circuit is always accompanied by a refrigerant leak, therefore this check allows to detect possible leaks in advance. The inspection is visual-type and it is sufficient to light the areas to be checked by means of a good electric torch. All piping fittings and joints (welded and not welded) must be checked since they are more subject to vibration; if some oil is detected, contact the closest After Sale Centre for intervention. The lubrication oil pressure must be checked through the appropriate manometer (when present); the oil pressure must always be at least 0,15 MPa (1,5 bar) higher than the value shown on the low pressure gauge (L.P.).

5.7.3 Vibrations check

The cooling circuit is composed of several rotating parts (fans, compressors, pumps, etc) equipped with bearings and they are balanced at the beginning; excessive vibrations, scrapings, striking, irregular noises such as whistles and creakings are all signals of mechanical troubles which might even generate serious and dangerous damages. The inspection must be performed while the unit is working and with the protection covers closed; in case of trouble, contact the closest technical service centre.

5.7.4 Check of terminals tightening

The vibrations the unit housing is subject to (and the electric box by transmission) can loosen the electric terminals thus causing malfunctionings; therefore, open the unit main switch and tighten all terminals screws; eventually, if it is always the same terminals to be loosened, contact the After Sales Service of EMICON A.C. S.p.A to report the fact.

5.7.5 Check of the gaskets on the centrifugal fans discharge

The centrifugal fans discharge is connected to the external skirt by means of a flexible gasket; the gasket must not be damaged and must not let air pass through. In this case, its replacement is necessary, therefore contact EMICON A.C. S. p. A. After Sales Service.

5.7.6 Compressors oil level check

Both scroll and semi-hermetic compressors are equipped with sight glasses to check the oil level.



WHILE CHECKING THE OIL LEVEL ALWAYS MAKE SURE THE FAN SECTION IS NOT OPEN

Oil level must be checked while the unit is working in steady conditions (therefore, after at least 15-20 minutes of operation). The oil level must be compared with the instructions shown on tags close to the sight glass; however, at least a quarter on the bottom of the sight glass must show the oil. An excessive presence of foam means that the thermostatic valves are not set up properly.

In case of trouble, contact EMICON A.C. S.P.A. After Sales Service.

5.7.7 Insulation condition check

All low temperature parts are heat insulated by means of muffs or of shaped plates to eliminate or reduce any heat leak which can cause a cooling capacity reduction as well as condensing phenomena or ice formation (which can be dangerous since in some conditions they can cause mechanical breakings). The check is of visual type; the insulation must not be damaged, detached from the supports or cracked. Bear in mind that in time the surface of insulating materials tends to slightly flake off without jeopardizing the insulation feature. Cracks, cuts or detachments must be repaired immediately by sticking or taping properly.

5.7.8 Supports and bearings check



While making the check, the unit main switch must be open ("0" position) and locked. The padlock key must be kept by the person in charge of the check.

All rotating parts are equipped with supports and bearings. Usually these parts do not need any maintenance and/or lubrication as they are a long-life type. A direct check of these parts is only possible on fans by rotating manually the fan wheel: its movement must be fluid, with no blockings or creakings and it must not show any lubricant leak. If any of the mentioned cases occurs, contact EMICON A.C. S.p.A. After Sales Service for repairing it.

5.7.9 Belts tension check - belts replacement



While making the check, the unit main switch must be open ("0" position) and locked. The padlock key must be kept by the person in charge of the check.

Centrifugal fans belts must be checked at regular intervals and must be replaced every two years of operation.

Press firmly the belt in the middle between the two pulleys: it must give way no more than 5 mm; if it gives way more than that, unblock the motor tightening screws, unscrew the belt-tensioner bolt after screwing the other belt tensioner bolt on the opposite side of the motor. Tighten the belt correctly, make sure the pulley engine is aligned to the duct (use the bolt on the opposite side of the belt tensioner to make it easier), overflow the motor on the base. To replace the belt, loosen the motor tightening screws, screw completely the belt tensioner bolt and close the motor to the fan housing, remove the belt from the pulleys, replace it with another belt having same form and size and tighten as above mentioned explained. In case of belt replacement, re-check the belt tension after a couple of days of operation

5.7.10 Humidity check of cooling circuit

Humidity inside the cooling circuit can cause many troubles (ice formation inside the expansion valve, acidification of compressors oil, etc.), therefore it is important to intervene immediately if this problem occurs. The cooling circuits are equipped with a light able to signal when humidity is present in the circuit; the sensor material located at the centre or on the border of the sight glass is bright green to signal a dry circuit or yellow to signal a wet circuit. On the sight glass the two referring colours for each status (dry / wet) are shown. If foam or bubbles can be seen through the sight glass, the refrigerant charge could be insufficient. This could be a sign for a refrigerant leak, then it is necessary to inform EMICON A.C. S.p.A After Sales Service. If humidity is detected inside the circuit, contact immediately EMICON A.C. S.p.A After Sales Service for repairing it.

5.7.11 Check of supply continuity to the crankcase heater



The unit main switch must be open ("O" position).

The compressors crankcase heater is essential to keep the oil free from refrigerant parts which otherwise might lead to possible seizure of compressor; the check must be performed by a common continuity tester checking there is supply continuity to the terminals after unplugging one of them from the terminal board. In case a supply interruption is detected, contact immediately EMICON A.C. S. p. A. After Sales Service for the shipment of the spare part of for the repair operation.

5.7.12 Regulation of overload protection relays

All electric motors are protected against overcurrent to prevent damage from over-loading the motor; for this reason, it is possible to install a regulation system which can interrupt current in case of overload or damage.

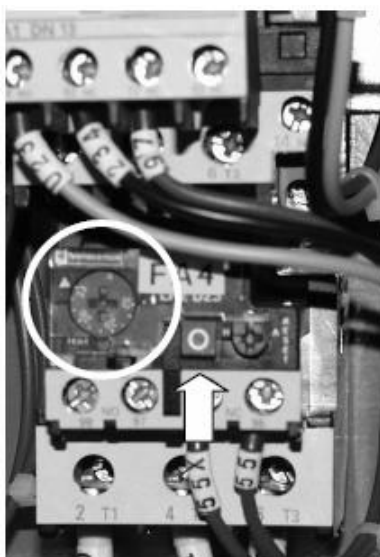

Picture 27



Picture 28

The pictures show two different types of remote control switches: the one shown on Picture 27 is equipped with a detached protection, while the one shown on Picture 28 is equipped with an incorporated protection (automatic circuit breaker). In both cases the regulation of the power-off switch value (maximum absorbed current per each motor phase) is performed by rotating the small wheel shown inside the white circle by means of a screwdriver till the referring triangle is in correspondence of the desired set value.



The maximum power-off value that can be set must not be higher than the absorbed current value shown on the electric motor tag.

When powered, the remote control switch can be opened by pressing the button indicated by the white arrow.

5.7.13 Replacement of protection fuses

Some parts of the unit circuits are protected by fuses enclosed in appropriate housings.



THE REPLACEMENT OF FUSES MUST BE EXCLUSIVELY PERFORMED WITH THE MAIN SWITCH OPEN .

Cartridge fuses

To replace the fuses, open the fuse holder, pull straight out on the small black handle down, remove the fuse/s and replace it/them with a new fuse having the same characteristics. Before replacing it, check the interrupting current rating of the broken fuse.



THE REPLACEMENT SHOULD ALWAYS HAVE THE SAME RATING AS THE ORIGINAL, SINCE A HIGHER RATING COULD CAUSE OVERHEATING, DAMAGE, FIRE.

Blade fuses

This kind of fuse is designed for higher interrupting ratings and it must be absolutely replaced by using an appropriate device. Never try to replace it by using inappropriate devices: possible damage to the fuse holder and wounds to the hands may happen. Proceed as per the following instructions:



Picture 29



Picture 30

1. Remove the fusebox cover.
2. Take the extractor tool "2" located inside the electrical panel.
3. Insert the puller into the fuse spring clips (see the white circle on Picture 29) and pull the extractor down till the clips are released.
4. Pull the extractor horizontally and firmly towards you; (any different movement could detach the cover from the fuse holder).
5. Press the button on the puller to remove the fuse (see Picture 32).
6. Insert the new fuse onto the puller and put it back into the fuse holder.
7. Release the puller by pressing the button.

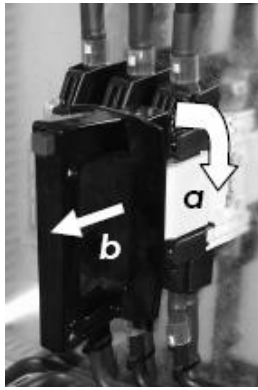

Picture 31



Picture 32



DO NOT TOUCH THE FUSE WITH NAKED HANDS: THE TEMPERATURE OF THE SURFACE COULD BE VERY ELEVATED AND COULD CAUSE BURNS.

5.7.14 Replacement of condensing fan motors



While making the check, the unit main switch must be open ("0" position) and locked. The padlock key must be kept by the person in charge of the check.

There are two types of fans: axial and centrifugal. In case of axial fans, being external-rotor type, it is recommended to replace completely the damaged fan after disconnecting the power supply (take due note of the original wiring). Mount the fan on its supports and ensure the blades do not scrape the blade guard and the supports, re-connect the electric wirings, check the rotation direction (if needed, reverse two phases). In case of centrifugal fans, after disconnecting the motor from the power supply, unscrew the fixing screws and remove it in the same way as described for the belts replacement (see par. 5.7.11); remove the pulley from the shaft by means of an extractor, after unscrewing the fixing dies.

The motor pulley is of adjustable type. If to unscrew the fixing dies the regulation must be changed, it is necessary to mark the original position with an indelible felt-tip pen and count the turns of the mobile part so that it is possible to reestablish exactly the original regulation once the operation is completed. Remove the protection paint from the shaft and from the new motor key (use a brush, solvent and some cloths); clean the inside part of pulley, lubricate with oil and install the pulley on the new motor making sure not to force the coupling. Once the pulley is entered into the shaft, insert it completely by means of a hard rubber mallet and block it definitely with the appropriate dies. Mount the motor and if needed reestablish the original pulley regulation and tighten the belt (see par. 5.7.11). Reconnect the motor and check the rotation by a short impulse given to the remote control switch after energizing it. If necessary, change the electric connection (inverting the connection of two phase cables) after disconnecting the power supply. Close the protection covers.

5.7.15 Replacement of compressors crankcase heaters



While making the check, the unit main switch must be open ("0" position) and locked. The padlock key must be kept by the person in charge of the check



Picture 33

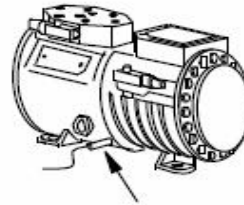

Picture 34

The tubular heater must be replaced by unscrewing the fixing screws (position indicated by the arrow in the picture) so that it can be easily removed; mount the new heater in the same position of the replaced one and push it against the compressor housing. The cartridge heater must be replaced by removing it from its location and installing in its place the new heater. In order to improve the heat transmission, use conductive paste or oil.



The cartridge must not stick out from its location; the protruding part may overheat and stop working.

5.7.16 Electrical cables check

The check is visual: the electrical cables must be not damaged or show abrasions, cuttings or overheating signs. In this case, replace them immediately.

5.7.17 Contactors status check

This operation must be performed by an expert electrician able to dismantle and re-install the remote control switches without damaging them. In case of blazed or blackened auxiliary switches or the whole remote control switch, make sure the contactor interrupting power is adequate to the power it runs.

5.8 Special maintenance operations

The operations listed here below must be performed only by skilled service personnel equipped with the suitable equipment and only when the unit is stopped and disconnected from the power supply.

	Operation	Frequency
1	Filling up of compressor oil	when necessary
2	Replacement of crankcase oil	when necessary
3	Check of cooling group performance	when necessary
4	Setting of cooling group pressure switches	when necessary
5	Replacement of cooling group pressure switches	when necessary
6	Replacement of filter cartridge	when necessary
7	Replacement of dehydrating filters	when necessary
8	Setting of cooling circuit valves	when necessary
9	Replacement of the cooling circuit valves	when necessary
10	Filling up / replacement of refrigerant	when necessary
11	Compressor replacement	when necessary
12	Replacement of compressor lubricant pump	when necessary
13	Heat exchanger replacement	when necessary
14	Condensing coil replacement	when necessary

For all the above mentioned operations and for any other operations not completely described on this manual, it is necessary to contact EMICON A.C. S.p.A. After Sales Service. To guarantee the unit a long operation life and to keep it always in the best efficiency conditions and to increase its service reliability, it is highly recommended to contact EMICON A.C. S.p.A. After Sales Service to draw up a maintenance contract.

6. DISMANTLING

When the unit has to be dismantled, drain the cooling circuit and collect the refrigerant gas by means of an adequate receiver, in order to protect people and environment.



Never release the gas contained in the cooling circuit in the environment.

When dismantling the unit or when replacing the compressor, carefully collect the oil compressor and deliver it to an authorized company for oil disposal.



Never release the oil compressor in the environment.

**DICHIARAZIONE CE DI CONFORMITÀ
EC DECLARATION OF CONFORMITY
CE-KONFORMITÄTSERKLÄRUNG
DECLARATION CE DE CONFORMITÉ**

Il Fabbricante

The Manufacturer

Der Hersteller

Le Fabricant

EMICON A.C. S.P.A.

via A. Volta, 49

47014 Meldola (FC)

tel. (+39) 0543/495611

fax. (+39) 0543/495612

e-mail emicon@emiconac.it

DICHIARA

che la macchina

DECLARES

that the machinery

ERKLÄRT

daß die Einheit

DECLARE

que l'unité

Modello

Model

Modell

Modèle

Matricola

Serial Nr.

Seriennr.

N.ro de série

*è conforme a tutte le
disposizioni pertinenti
delle direttive*

2004/108/EC

*in quanto è stata
progettata, costruita e
collaudata in accordo
con le seguenti Norme*

EN 61000-6-1

EN 61000-6-2

EN 61000-6-3

EN 61000-6-4

*fulfils all the relevant
provisions of the
directives*

2006/42/EC

*because it has been
designed, manufactured
and tested according to
the following Standards*

EN ISO 12100-1

EN ISO 12100-2

*den folgenden
Vorschriften entspricht*

*da sie in Übereinstimmung
mit den folgenden
Normen geplant gebaut
und getestet wurde*

*est conforme aux
dispositions*

2006/95/EC

*étant l'appareil conçu,
réalisé et testé dans le
respect des normes
suivantes*

EN 60204-1

EN 60335-1

EN 60335-2-40

EN 60439-1

AUTORIZZA

*a costituire il Fascicolo
Technico.*

AUTHORISES

Romano Santucci

via A Volta, 49

47014 Meldola (FC)

*to compile its Technical
File.*

AUTORISIERT

*die technischen
Unterlagen zu erstellen*

AUTORISE

*à réaliser le dossier
technique.*

Meldola, ___ / ___ / _____

Romano Santucci

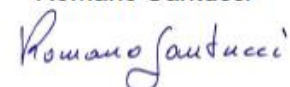

Technical Manager



Emicon A.C. S.p.a. Via A.Volta 49 Meldola Tel. +39 0543 495611 Fax +39 0543 495612